



Optional Bluetooth Communication



Easy to install Rechargeable Battery



TWN Handheld Portable Indicator

Caston II Plus

Crane Scale

The Caston II Plus is a full featured industrial crane scale that is easy to see, easy to use, versatile, unquestionably safe, and designed to last!

- Available in 1,000 x 0.5 lbs, 2,000 x 1 lb, 5,000 x 1 lb, and 10,000 x 2 lbs
- Easy to read 1.2" LED Display
- Rechargeable battery with charger
- Spare battery included
- Wireless Remote Control Standard
- Optional Field Retrofittable TWN Handheld Portable Indicator



Caston II Plus ▶



◀ Wireless Remote Control



www.cas-usa.com

Caston II Plus | Crane Scale

Model	Standard	CAST2-PLUS(1K)	CAST2-PLUS(2K)	CAST2-PLUS(5K)	CAST2-PLUS(10K)
	Bluetooth	CST2+(1K)BT	CST2+(2K)BT	CST2+(5K)BT	CST2+(10K)BT
Weighing Capacity		1,000 x 0.5 lbs 500 x 0.2 kg	2,000 x 1 lb 1,000 x 0.5 kg	5,000 x 1 lbs 2,000 x 0.5 kg	10,000 x 2 lbs 5,000 x 1 kg
Maximum Tare	Full Tare				
Display Type	LED - 1.2 inch				
Display Designators	Zero, Tare, Batt				
Operating Power	DC 6V				
Power Source	AC 120V, 60 Hz				
Power Consumption	1 W				
Operating Temp	14°F ~ 104°F / -10°C ~ +40°C				
Product Weight	33.1 lbs / 15 kg	37.5 lbs / 17 kg		44.1 lbs / 20 kg	
Safe Overload	150% of rated capacity				
Warranty	2 Years				

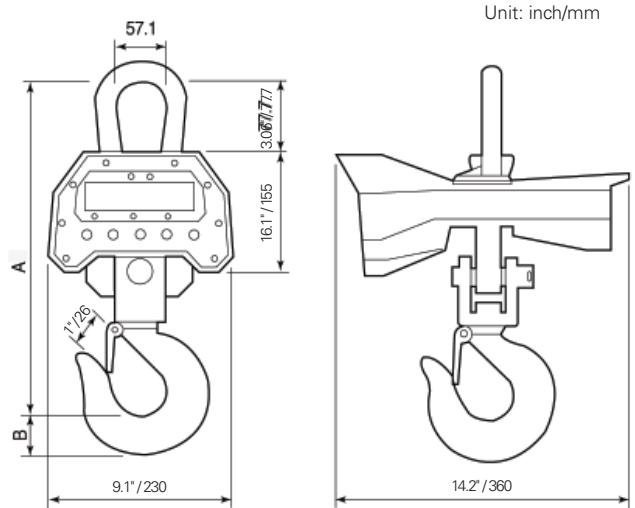

Already have a *Caston II Plus* Crane Scale and want Bluetooth connectivity? No problem. Simply install the optional Bluetooth Field Retrofit Kit and the TWN Portable Handheld Indicator for a fully operational Bluetooth crane scale.

Model	A	B
CAST2-PLUS(1K)	13.78" / 350	1.18" / 30
CAST2-PLUS(2K)	13.78" / 350	1.18" / 30
CAST2-PLUS(5K)	16.93" / 430	1.75" / 44.5
CAST2-PLUS(10K)	18.66" / 474	1.75" / 44.5

TWN Handheld Indicator

- Light weight, durable & portable
- Easy to see - simple to operate
- Wireless Connectivity
- Increased Functionality
- Built-in Rechargeable Battery
- Sun Visor



This portable handheld indicator is both durable and functional. The TWN's design incorporates a built-in rechargeable battery and offers Bluetooth wireless communication capabilities that enable transmissions in excess of 300 feet / 100 meters.

The CAS TWN Handheld Indicator utilizes a high contrast, 320 x 240, TFT LCD display with a screen visor and an alphanumeric and function style keypad housed in a light weight protective enclosure.

For data management needs, the TWN is supplied with enough on-board memory for 100 items and 5,000 transactions (including time, date, and gross weight). A wireless or wired printer

can be used for printing needs or simply utilize the USB to PC connection to upload/download weighing data including item number, item name, and header text to a connected PC. Increased data management capabilities are also available with the addition of CAS TW-Works PC software.

Communication Type	Bluetooth
Communication Rate	9,600 bps
Communication Distance	Max: 300ft/100m
Display	High contrast 320 x 240 TFT LCD
Enclosure	Light weight industrial grade NEMA 4/IP65
Memory	100 items/5,000 transactions incl time/date/gross wt
Battery Charging Time	Approx 5-6 hrs
Options	Wireless or Wired Printer
Power	DC 3.6V 4,400mA rechargeable battery DC 4.2V adapter
Operating Temp	-10°C ~ +40°C
Interface	USB : PC connection RS-232C : Mobile printer connection
Dimensions	4.1 (W) x 8 (H) x 2.9 (D) - Inches 104.7 (W) x 204 (H) x 74.3 (D) - MM
Product Weight	1.1 lbs/0.5 kg



99 Murray Hill Parkway
East Rutherford, NJ 07073
TEL: (201) 933-9002
FAX: (201) 933-9025
<http://www.cas-usa.com>

Specifications are subject to change for improvement without prior notice.