

PALLET SCALE

CPS SERIES

OWNER'S MANUAL

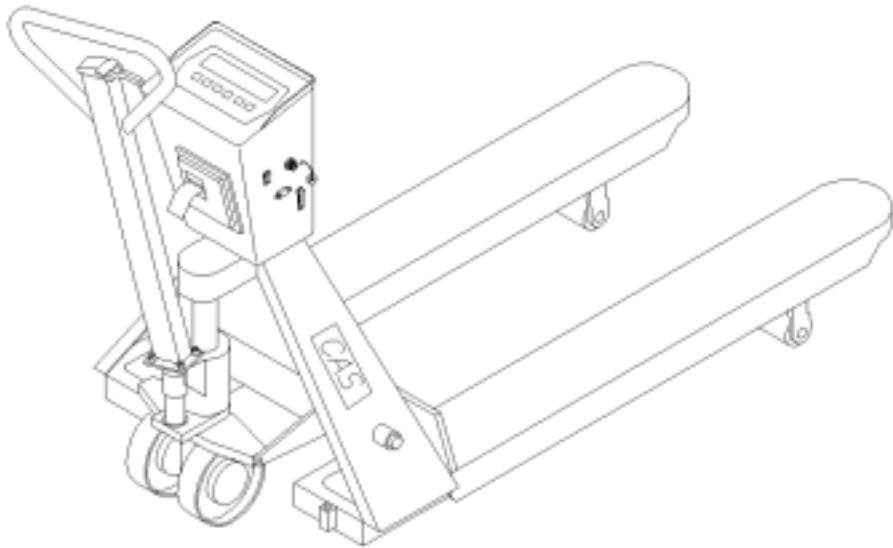

CAS

<h1>Table of Contents</h1>		
1.	PREFACE	3
2.	OVERALL VIEW	4
3.	SPECIFICATIONS	5
4.	DIMENSIONS	5
5.	FRONT PANEL	6
6.	RS-232C (OPTION)	8
7.	OPERATIONS	10
8.	HOW TO CHARGE	12
9.	TEST MODE	13
10.	SET MODE	14
11.	ERROR MESSAGE AND TROUBLE SHOOTING	19

1. PREFACE

Thank you for the purchasing of our CAS CPS Series.

These series have been designed with CAS reliability, under rigid quality control and with outstanding performances. Your speciality departments can enjoy with these high quality reliable CAS products. These electronic load cell scales eliminate the all the moving parts and furnish an accurate digital display of all information. We believe that your needs will be satisfied and you will have proper reliability in variable weight.

This manual will help you with proper operations and care of the CPS scales. Please keep it handy for the future references.

CAUTIONS

Do not press the keys hardly, for the keys are in operation with soft touch.

Do not use ignitable material for cleaning.

Keep away CI-2001B from the rain.

Avoid sudden temperature change.

Do not install CI-2001B in a place with high voltage and excessive electrical noises.

Keep it in dry place.

Do not use under direct rays and dusty place.

Do not use at the place with excessive electrical noises and vibration.

FEATURES

CAS PALLET SCALE (CPS) weigh the pallet loads with accuracy.

CPS's "lift and read" technology speed the loading and weighing process.

We have 1000kg and 2000kg capacity models.

Digital indicator displays the weight.

Built-in printer(optional). You can record the weight of loads with printer.

Built-in battery. You can use this scale without power outlet.

NOTICE : Specifications are subject to change for improvement without notice.

2. OVERALL VIEW

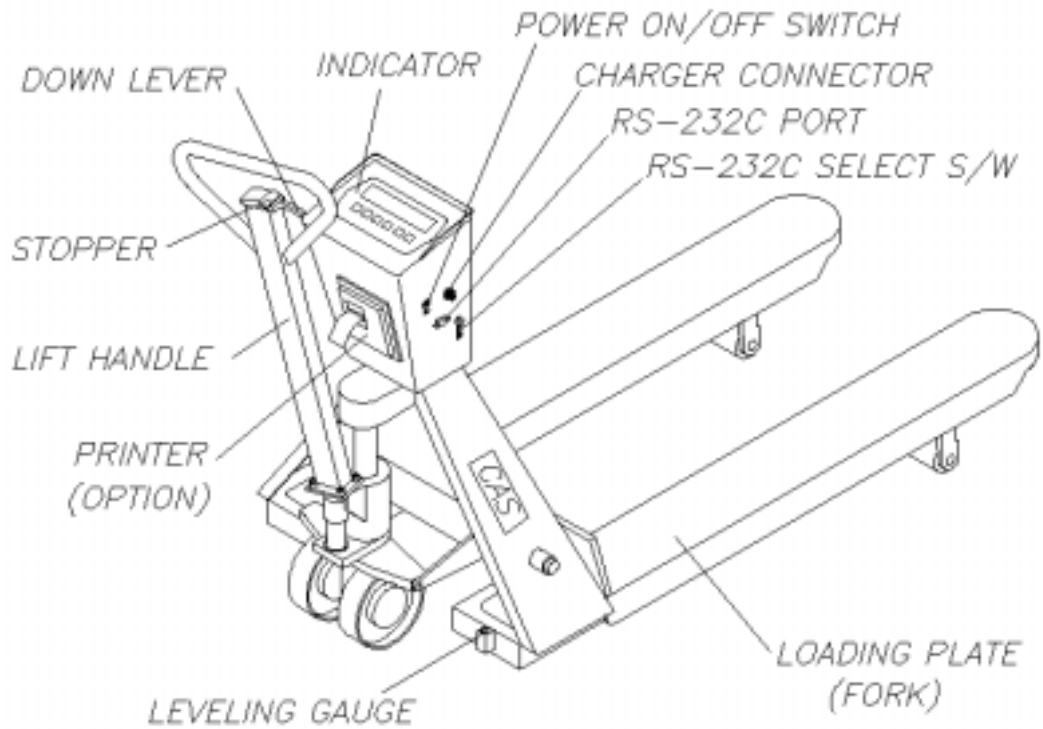

3. SPECIFICATIONS

MODEL NAME		CPS-1			CPS-2		
SIZE	TYPE	A	B	C	A	B	C
	W	540	620	705	540	620	705
	L	1080	1080	1200	1080	1080	1200
CAPACITY		1000kg×0.5kg (2000lb×1lb)			2000kg×1kg (5000lb×2lb)		
OVERLOAD PROTECTION		1500kg (3000lb)			2500kg (5500lb)		
WEIGHT DISPLAY		5digit LCD (HEIGHT 25mm)					
POWER SUPPLY		DC6V/ 10AH BATTERY (AC 110V/220V CHARGER)					
ACCURACY		0.1%					
OPTION		PRINTER, PC Connection					
TEMPERATURE RANGE		-10 ~ 40					

4. DIMENSIONS

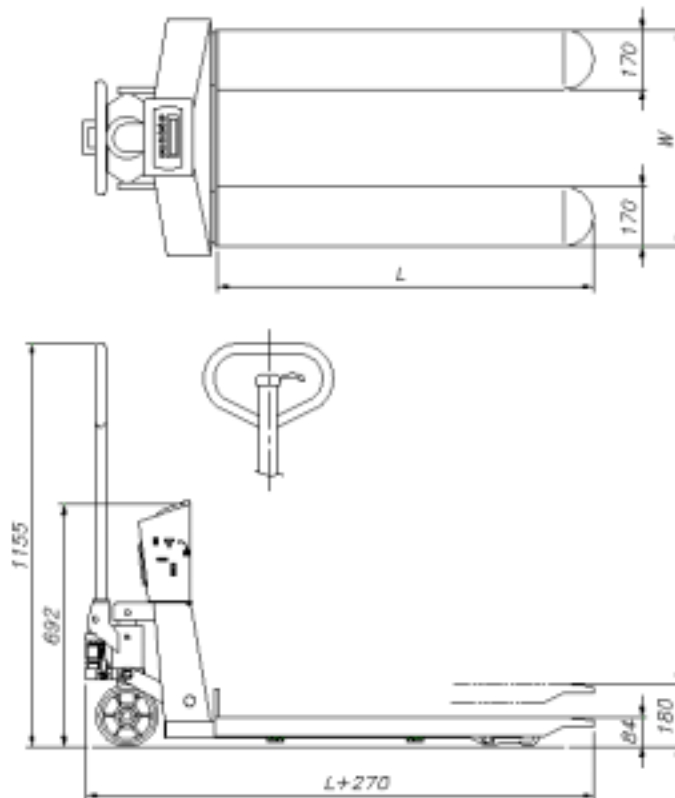

5. FRONT PANEL

kg version.



kg/lb version.



(1) Display lamp

lb lamp : ON when the weight unit is pound. [lb]

kg lamp : ON when the weight unit is kilogram. [kg]

lamp : ON when the weight is stable.

ZERO lamp : ON when the current weight is 0 kg. (0 lb).

NET lamp : ON when the current weight is NET weight.

BAT lamp : In case of rechargeable battery, display the battery recharging time.

Battery warning lamp

If Battery warning lamp turn on, CPS will power off after about 30 seconds.

(2) Keyboard

, Key

Available keys instead of numeric keys.

: Change the set value

 Increase the first place value to 1

: Change the digit of the set value

 Move to the left by 1 place

USAGE : Input the numeral value in TEST, SET mode.

ZERO Key : Return the display to 0.

TARE Key

Use container in weighing.

Current weight is memorized as tare weight.

If you press TARE key in unload condition, Tare setting is released.

GROSS/NET Key

Display gross and net weight by turn.

GROSS lamp on - gross weight

NET lamp on - net weight

In case tare weight is REGISTERED, tare and item's total weight is G. weight and only item's weight is N. weight.

kg/lb Key (Only kg/lb version)

Toggles between lb and kg units.

PRINT Key

1. PRINT Key : Total Print key (by pressing "PRINT" key more than 3 second.)
2. HOLD Key

* key(Only kg version)

1. Total print key. (F09 - 1)
2. Hold key. (F09 - 2)

ON/OFF Key

1. Back light ON/OFF key
2. ON/OFF key (by pressing key more than 3 second.)
3. Store current condition and exit in TEST, SET mode.

6. RS-232C (OPTION)

(1) How to RS-232C Select switch

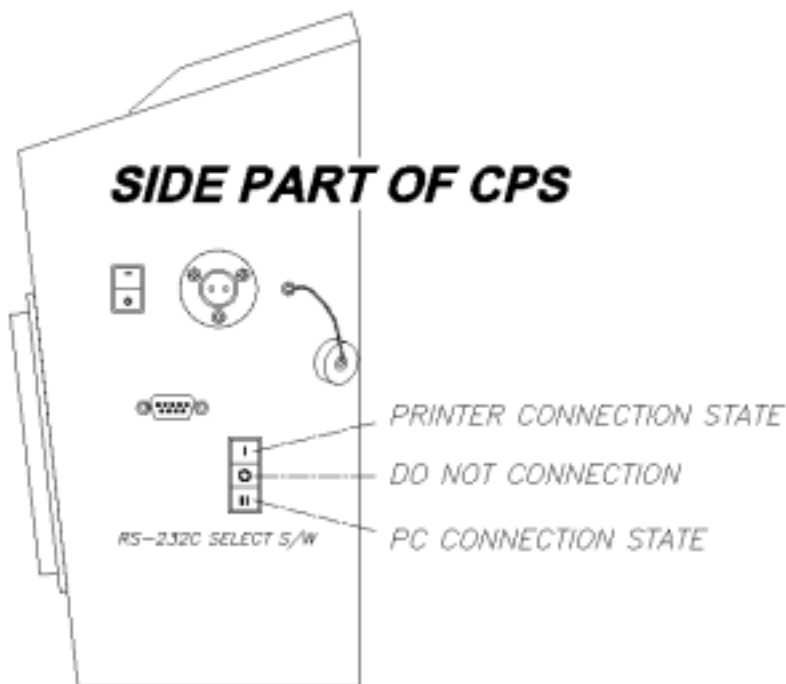

(2) How to connect PC

Connect the serial port on the rear panel of the indicator to serial port of PC as follows.

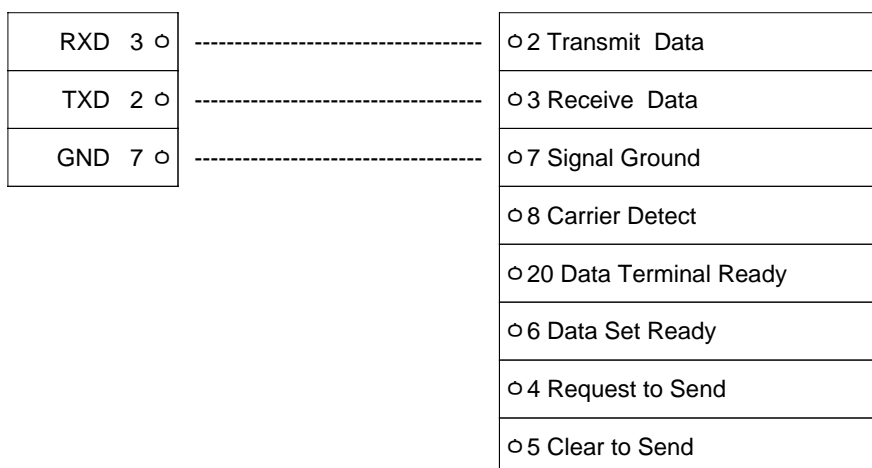

9 pin port(Male)
RS-232C port of CPS Series

25 pin port(Female)
Serial port of computer

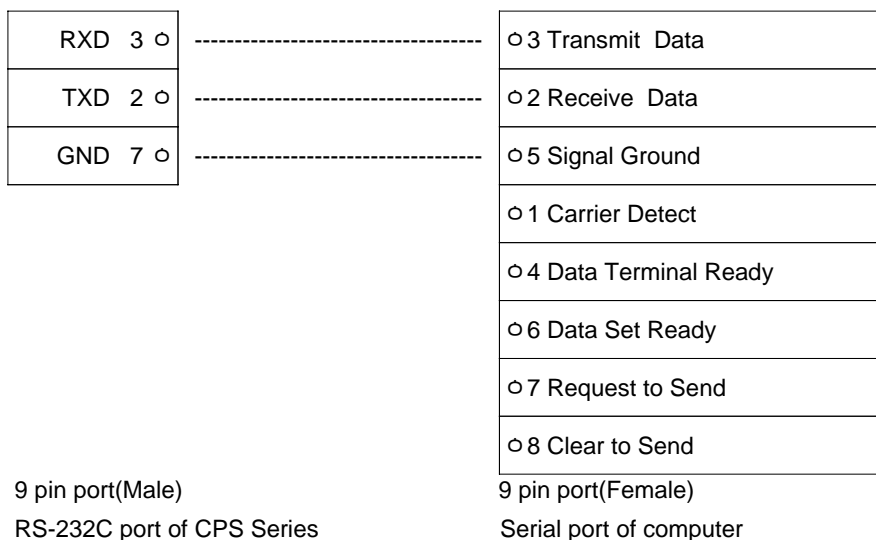

(3) How to connect Sub display

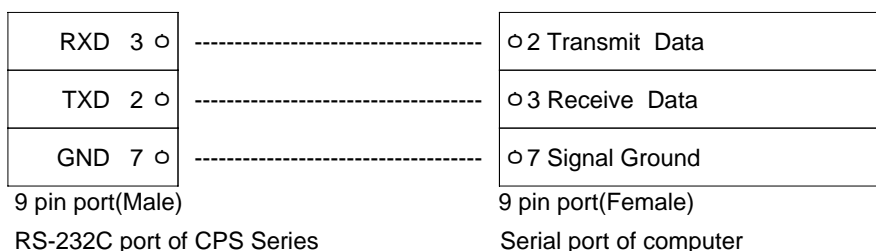

(4) Data format

- ① Baud rate : 1200 bps - 19200 bps
Set Baud rate in SET mode. (See F20 at page 30)
- ② Data bit: 8, Stop bit: 1, Parity bit: None
- ③ Code : ASCII
- ④ When data is sent to computer? : Set in SET mode(See F12 at page 31).
- ⑤ Format

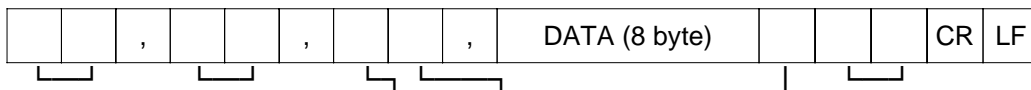

US(Unstable)
GS(GROSS weight)
Device ID
Lamp condition byte
Empty
Unit (kg/t)

ST(Stable)
NT(NET weight)

OL(Overload)

- Device ID : Transmit 1 byte so that the receiver can receive data selectively which indicator sent.(Device ID is selected in F10 .
- Weight Data (8 byte)
 - a. 13.5kg : ',' , ',' , ',' , ',' , '1' , '3' , ',' , '5'
 - b. 135kg : ',' , ',' , ',' , ',' , '1' , '3' , '5' , ','
 - c. -135kg : '-' , ',' , ',' , ',' , '1' , '3' , '5' , ','

6. OPERATIONS

(1) How to assembly

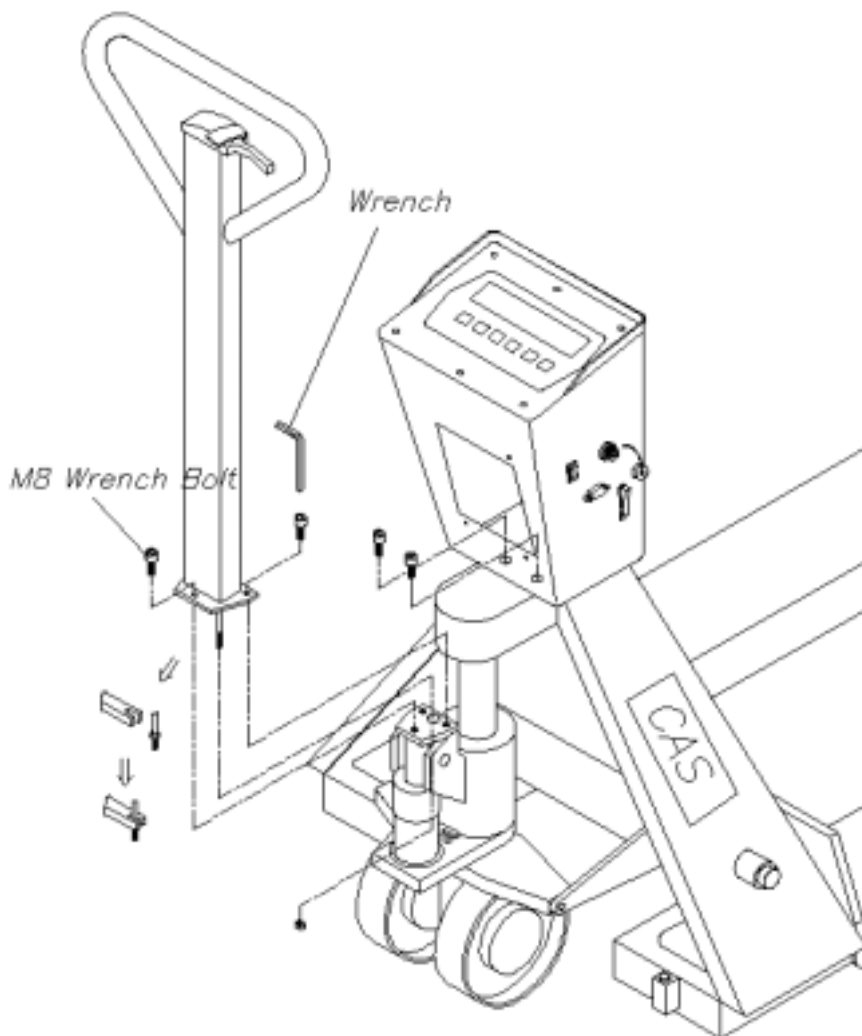

(2) Operations

1. Turn the power switch ON.

The power switch is located on the right side of the indicator.

WARNING : Avoid leaving **ANY** load before turn the power switch ON.

2. Pressing ON key of front panel.
3. Display will show "0", make sure that ZERO lamp is ON.
4. When the FORK lift the load, weighing is performed.

WARNING : Fork have to properly level so as to center bubble of the leveling gauge inside the indicated circle and fork truck should not move.

5. If you want to adjust zero range, press the ZERO key.
6. If you want to use tare function, press the TARE key.
If you don't want to use tare function any more, remove the container(pallet) and press the TARE key.

7. If you want to down the fork, pull the DOWN LEVER.

If you want to lift the fork, press the STOPPER and operate the LIFT HANDLE.

8. HOW TO CHARGE

1. Plug the charger into a AC socket and make sure that the socket's power is within the charger's operating range.
Open the socket's cover located on the right side of indicator and then connect to the connector. (See Fig 1.)
2. Depending on the charging state, the lamp located on the charger will be ON.
3. When the battery is fully charged, the charger lamp will be ON.
4. It takes about 8 hours to fully charge the battery.

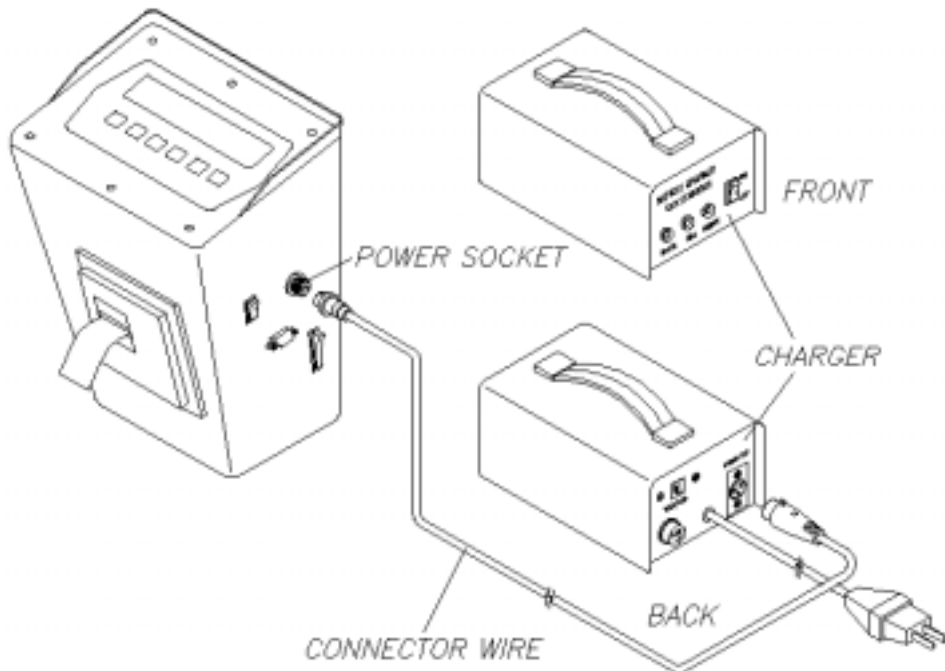

(Fig 1)

9. TEST MODE

(1) HOW TO ENTER

Turn on the power while pressing the 'ZERO' key and TEST menu starts.

(2) AVAILABLE KEYS & CONVERTING METHOD

KEY : Increase the first place set value to 1

KEY : Move to the left by 1 place of the set value.

PRINT(kg/lb version) or *(kg version)KEY : Move to a weight measure mode

ON/OFF KEY : Move into next menu.

(3) TEST MENU(TEST1 - TEST 5)

TEST 1 : Key test

TEST 2 : LCD display test

TEST 3 : Load cell test and A/D conversion test

TEST 5 : Print test

TEST 1

FUNCTION : Key test		
KEY	LCD DISPLAY	DESCRIPTION
ON/OFF key : Next menu Other key : Perform test	tEst 1 1	Test 1 condition. Press the key to be test and the No. and code of the key is displayed

<Key code>

KEY	CODE	KEY	CODE	KEY	CODE
ZERO	1	TARE	2	GROSS/NET	3
PRINT (kg version)	4	· (kg version)	5	ON/OFF	6
kg/lb (kg/lb version)	4	PRINT (kg/lb version)	5		

TEST 2

FUNCTION : LCD display test		
KEY	LCD DISPLAY	DESCRIPTION
	tEst 2 	Test 2 condition. TEST 2 is performed automatically

Ref 1. Program is automatically shifted to menu selection mode after completing.

TEST 3

FUNCTION : A/D conversion test (L/C test)		
KEY	LCD DISPLAY	DESCRIPTION
ON/OFF key : Next menu Other key : Perform test	tEst 3 5500	Test 3 condition. Display digital value of current weight. This value means converted digital value.

Ref 1. Check whether digital value is changing. If the digital value is fixed or zero is displayed. Please check the connection of the load cell.

TEST 5

FUNCTION : Printer test		
KEY	LCD DISPLAY	DESCRIPTION
ON/OFF key : Exit test mode Other keys : Perform test	tEst 5 G00d Err06	Test 5 condition. No error in printer. Check printer connector

Ref 1. "Good" message is displayed if the printer connection and specification is done correctly. if not, "Err 06" message is displayed.

Ref 2. The test output format of printer is like follows.

TEST OK

10. SET MODE

(1) HOW TO ENTER

Turn on the power while pressing the "TARE" key and SET menu starts.

(2) AVAILABLE KEYS & CONVERTING METHOD

KEY : Increase the first place set value to 1

KEY : Move to the left by 1 place of the set value.

PRINT(kg/lb version)KEY, *(kg version)KEY : Move to a weight measure mode

ON/OFF KEY : Move into next menu.

(3) SET VALUE CONVERSION MENU (F01 - F18)

F01 : Select the primary base unit (kg/lb)

F02 : Designation of serial port usage

F03 : Automatic zero condition set

F04 : Digital Filter

F07 : Weight Back-up (Power-on Actual Weight)

F08 : "PRINT" Key Usage

F10 : Device ID

F11 : Designation of Serial Interface Baud rate

F12 : Designation of Serial Interface output mode

F13 : Set HOLD type

F14 : Select of clock option

F17 : Print line feed

F18 : Display mode

Select the primary base unit (Only kg/lb version)		
F01	0	primary unit is kg
	1	primary unit is lb

Serial port usage		
F02	0	Not Usage
	1	Connection to serial Printer

Automatic Zero tracking			
F03	0	None Automatic zero	
	1	0.5 digit	Auto zero tracking will automatically bring the display back to "0" when there are small deviations.
	~	.	
		.	
9	4.5 digit		

Digital Filter			
F04	0	None Digital filter	
	1	1 : Less Vibration	Adjust the set value according to the condition.
	~	.	
		.	
9	9 : Much Vibration		

Select the weight back-up mode		
F07	0	Weight back-up is off (Power on Zero)
	1	Weight back-up is on

"PRINT" Key Usage (Only kg/lb version)		
F08	0	Not used
	1	- Print key - Total Print key (by pressing "PRINT" key more than 3 second)
	2	HOLD Key

" * " Key Usage (Only kg version)

F09	0	Not used
	1	Total Print key
	2	HOLD Key

Device ID

F10	00	Device ID "00"	It is used the no. of indicator when system is connected.
	~	.	
	99	Device ID "99"	

Baud Rate

F11	0	600 bps
	1	1200 bps
	2	2400 bps
	3	4800 bps
	4	9600 bps
	5	19200 bps

Output Mode

F12	0	No data output
	1	Stream Mode
	2	Transmit only in stable condition
	3	Transmit when data is required Request signal : device ID (F10 : Device ID) (In case F10 : 1, Send Hex Value 01h in Computer)

Set HOLD type

F13	0	Average hold : Compute the average weight of oscillating weights.
	1	Peak hold : Compute the maximum weight among oscillating weights.
	2	Sampling hold : Compute the current weight.

Select Option Clock		
F14	0	Not use Clock
	1	Use Clock

Change Date/Time (Ex. 1998/12/11 13:10:01)		
: Increase of no. : Shift of digit LIGHT : Store and move into next menu	LCDisplay	Meaning
	C1 98	Year : 98
	C2 12	Month : 12
	C3 11	Day : 11
	C4 13	Hour : 13
	C5 10	Minute : 10
	C6 01	Second : 01

Print line feed		
F17	1	1 Line feed
	2	2 Line feed
	3	3 Line feed
	4	4 Line feed
	5	5 Line feed

Display mode		
F18	0	Always display weight in Normal.
	1	When stable, display weight in Normal.

11. Error message & Troubleshooting

Err 01

Reason

The weight is too unstable to initialize the scale.

Troubleshooting

Lay the scale on a flat place and turn on the power.

Err 02

Reason

Load cell connection failure or error in A/D conversion part.

Troubleshooting

Check the load cell connector to see if the polarity of signal is reversed.

Err 06

Reason

Error in printer connection

Troubleshooting

Check with printer connector

If there is no problem with printer and printer connector, please request A/S to head office.

Err 08

Reason

The ZERO key or TARE key is adjusted not to be operated under the unstable condition.

Troubleshooting

Press Zero or Tare key in stable condition

Err 09

Reason

Current weight deviates from zero range.

Troubleshooting

Press the ZERO key within 10% of the maximum capacity.

Err 10

Reason

Tare weight exceeds the maximum capacity of the scale.

Troubleshooting

Set the tare to be smaller than the maximum capacity.

Otherwise the maximum capacity is reset to be larger than the tare to be set in the calibration menu, and reset the calibration using weight.

Err 13

Reason

The zero range deviates from the set range.

Troubleshooting

Confirm that there is nothing on the weighing platform.

If nothing exist, do calibration in CAL mode.

Over

Reason

The weight on platform is too heavy to be measured.

Troubleshooting

Do not load the item exceeds the maximum tolerance.

If the load cell is damaged, the load cell should be replace.